

# PITELUMEC

## *Thumper 30* DOWN THE HOLE HAMMER



**THUMPER 30 FOR HOLE DIAMETER 90 - 105MM**

# PNEUMEC THUMPER 30 3" DOWN THE HOLE HAMMER

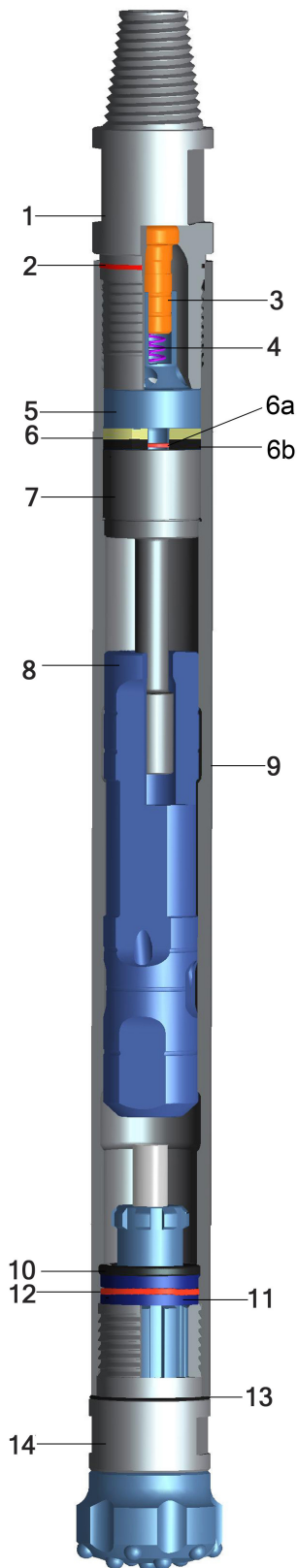

## THUMPER 30 HAMMER PARTS LIST

1.	BACKHEAD 2-3/8" API REG PIN	HSP3S1T1M
2.	BACKHEAD "O" RING	HSP3S2
3.	CHECKVALVE	HSP3S3
4.	CHECK VALVE SPRING	HSP3S4
5.	VALVE CHEST	HSP3S5
6.	MAKE UP RING	HSP3S22
6a.	MAKE UP PLATE "O" RING	HSP3S6
6b.	MAKE UP PLATE	HSP3S23
7.	CONTROL TUBE	HSP3S8
8.	PISTON	HSP3S12M33
9.	WEARSLEEVE	HSP3S18
10.	PISTON RING	HSP3S25
11.	BIT RETAINERS	HSP3S15M33
12.	BIT RETAINER "O" RING	HSP3S16
13.	CHUCK RELEASE WASHER	HSP3S21
14.	CHUCK MACH33	HSP3S19M33
15.	COMPLETE HAMMER MACH33	HAM3SM33THP

## THUMPER 30 HAMMER SPECIFICATIONS

DIAMETER	79MM
LENGTH	880MM
PISTON WEIGHT	5KG
HAMMER WEIGHT	26KG
HOLE DIAMETER	90MM – 105MM
BACKHEAD CONNECTION	2-3/8" API REG PIN
SHANK TYPE	MACH33

## THUMPER 30 HAMMER AIR CONSUMPTION

PRESSURE (BAR / PSI)	CFM	M <sup>3</sup> /MIN
10.3 / 150	140	3.9
13.8 / 200	205	5.8
17.2 / 250	265	7.5
24.1 / 350	440	12.5



**PNEUMEC COMPANY LIMITED**

1st Floor, Tin On Sing Comm. Bldg., 41-43 Graham St. Central, H.K.

Tel : (852) 2180 9922

Fax : (852) 2180 9982

Website : [www.pneumec.com](http://www.pneumec.com)

email : [info@pneumec.com](mailto:info@pneumec.com)